

## INSTRUCTIONS FOR USE OF BALUSTER MOLD

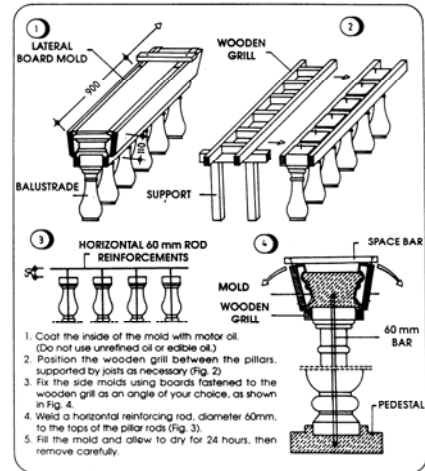
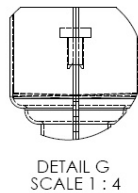
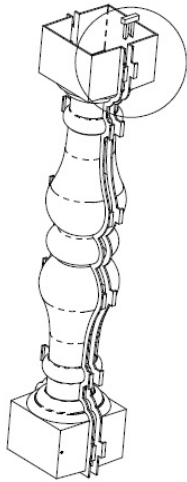

The first step is to close two half's together with plastic pins. . Cut ½” rebar to place in the middle of mold to add strength to baluster.

The second step is to mix the concrete 1:3, granulation 0-1 cm (1 shovel Portland cement, 3 shovels sand).

For perfect outcome use white cement, to mix the concrete 1:2, granulation 0-1 cm (1 shovel white cement, 2 shovels sand)

The third step is when filling cement mix in mold rotates often the mold to ensure proper smoothness in finished product.

Drying time in summer 12 hours, otherwise allow 24 hours.

Once dry place mold horizontally and remove each half of mold carefully. Place baluster in the desired curing area carefully. To do molds again, simply repeat instructions from beginning.

Contact Address:

Bruno Pahljina  
Po.Box. 424  
Madeira Park B.C.  
V0N 2H0  
Canada

E-mail address: [ez-molds@dccnet.com](mailto:ez-molds@dccnet.com)

