

## INSTRUCTIONS FOR USE

. See sample picture.

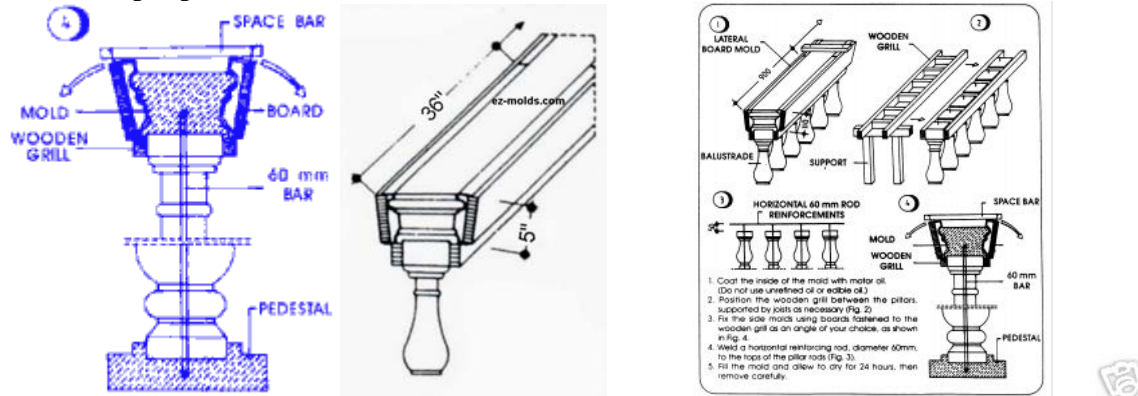

The first step is to place the mold on the inside of the 2" by 6" fir lumber, attach mold with small flathead screws to the 2" by 6".

The second step is to coat mold with clear hydraulic oil to avoid the cement sticking to the mold.

The third step is to mix the concrete 1:2, granulation 0-1 cm (1 shovel Portland cement, 2 shovels sand).

The fourth step is when filling cement into the railing between the railing molds, tap it with a hammer lightly on the sides and underneath on your lateral frame between the balusters.

Drying time in summer 12 hours, otherwise allow 24 hours.

To do molds again, simply repeat instructions from the beginning.

Contact Address:

Bruno Pahljina  
Po.Box. 424  
Madeira Park B.C.  
V0N 2H0  
Canada

E-mail address: [ez-molds@dccnet.com](mailto:ez-molds@dccnet.com)